



UNIDRIVE M100

Manufacturing Automation drive
Value drive with quality and performance
for open loop applications



- ➔ Unidrive M100
- Unidrive M200
- Unidrive M300
- Unidrive M400
- Unidrive M600
- Unidrive M700
- Unidrive M800

0.25 kW - 7.5 kW Heavy Duty
(0.33 - 10 hp)
100 V | 200 V | 400 V



The Unidrive M Manufacturing Automation drive family

Unidrive M – A Manufacturing Automation drive family tailored to customer needs

Led by the results of extensive customer-driven market research, we have tailored seven Unidrive M feature-sets to specific application needs identified within Manufacturing Automation. The Unidrive M100 is a value drive that provides class leading quality and performance for open loop applications.

For more information on the full Unidrive M family, please download the Unidrive M Overview brochure or the 'Discover Unidrive M' App (available on the App Store, Android and online) via www.UnidriveM.com.



Unidrive M100 features

M101 variant has additional speed reference potentiometer

Optional AI-Back-up Adaptor allows the drive to use an SD card for parameter cloning and acts as an input for 24 V back-up

LED keypad fitted as standard for quick commissioning and easy use

User-friendly control connections
1 x Analog input
4 x Digital I/O

Drive rated to IP21 / UL open class (NEMA 1) as standard

Conduit kits are available to meet UL Type 1 rating as standard

Easy-to-remove terminal cover with tool-less close system (patent pending)

Conventional surface and DIN rail mounting (DIN rail mounting available on size 1 and 2 only)

Easy-to-disconnect internal EMC filter

User-friendly power connections for open loop vector or V/Hz induction motor control

Robust cable management system providing grounding point for shielded control and power cables



Terminal layout

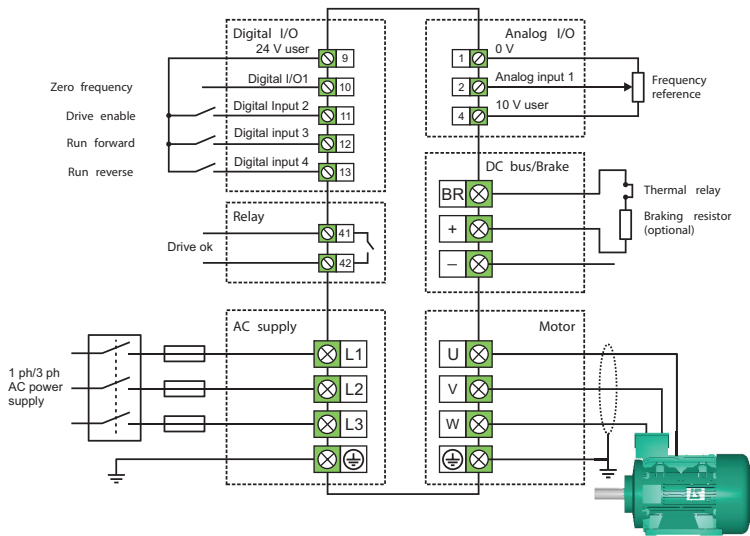

Unidrive M100 AC drive at a glance

Value drive with quality and performance for open loop Manufacturing Automation applications

As part of the Unidrive M family, dedicated to Manufacturing Automation, M100 delivers an economical open loop drive for general applications, with Control Techniques' proven quality and class leading motor operation.



Quick and easy to install and configure

Unidrive M100 has a simple fixed LED keypad for easy configuration, monitoring and diagnostics, with the 10 most commonly used parameters listed on the front of the drive. The M101 provides an additional speed reference potentiometer, enhancing customer interface choice.

Robust design

After extensive customer research, Unidrive M100 has been designed and tested for leading reliability in manufacturing environments. It features:

- Unique advanced cooling design featuring a patented flow system that helps cool the drive more effectively while protecting internal components
- Conformally coated PCBs
- 150 % overload for 60 s
- Wide supply voltage tolerance
- Drive meets IP21 as standard
- Higher temperature operation with de-rating
- Intelligent 3 speed user-replaceable cooling fan with patented fan-fail detection circuit

Fast parameter transfer without mains power

For fast, serial machine production the AI-Back-up Adaptor option plugs into the top of the drive to allow configuration settings to be copied without the need to apply mains power. Files are stored on an SD memory card for easy handling and quick configuration.

Reduce machine size and cost

Unidrive M100's compact drive dimensions are among the smallest in class at every power rating. They provide a powerful and economical Manufacturing Automation solution.

Power system flexibility

Unidrive M's power stage enhances flexibility and energy efficiency:

- Low losses, up to 98 % efficient.
- Low power standby mode. In some applications, drives can sit idle for significant periods; M100's reduced standby power saves energy.
- Intelligently controlled 3-speed cooling fan adjusts to the motor load and environmental conditions. This results in power saving, extended fan life and reduced acoustic noise.
- Silent motor operation with high PWM switching frequencies up to 16 kHz.

Motor control mode

Unidrive M100 provides open loop vector or V/Hz induction motor control providing good performance and easy configuration. V/Hz can be used in multi-motor systems.

Typical applications:

Speed control for conveyors, fans, pumps and mixers.



Conveyor line application

Unidrive M100 ratings and specifications

100/120 Vac ±10 %				
Order Code	Supply Phases	Heavy Duty		
		Max Continuous Current (A)	Motor Shaft Power (kW)	Motor Shaft Power (HP)
M10x-011 00017	1	1.7	0.25	0.33
M10x-011 00024	1	2.4	0.37	0.5
M10x-021 00042	1	4.2	0.75	1
M10x-021 00056	1	5.6	1.1	1.5

200/240 Vac ±10 %				
Order Code	Supply Phases	Heavy Duty		
		Max Continuous Current (A)	Motor Shaft Power (kW)	Motor Shaft Power (HP)
M10x-012 00017	1	1.7	0.25	0.33
M10x-012 00024	1	2.4	0.37	0.5
M10x-012 00033	1	3.3	0.55	0.75
M10x-012 00042	1	4.2	0.75	1
M10x-022 00024	1/3	2.4	0.37	0.5
M10x-022 00033	1/3	3.3	0.55	0.75
M10x-022 00042	1/3	4.2	0.75	1
M10x-022 00056	1/3	5.6	1.1	1.5
M10x-022 00075	1/3	7.5	1.5	2
M10x-032 00100	1/3	10	2.2	3
M10x-042 00133	1/3	13.3	3	3
M10x-042 00176	3	17.6	4	5

380/480 Vac ±10 %				
Order Code	Supply Phases	Heavy Duty		
		Max Continuous Current (A)	Motor Shaft Power (kW)	Motor Shaft Power (HP)
M10x-024 00013	3	1.3	0.37	0.5
M10x-024 00018	3	1.8	0.55	0.75
M10x-024 00023	3	2.3	0.75	1
M10x-024 00032	3	3.2	1.1	1.5
M10x-024 00041	3	4.1	1.5	2
M10x-034 00056	3	5.6	2.2	3
M10x-034 00073	3	7.3	3	3
M10x-034 00094	3	9.4	4	5
M10x-044 00135	3	13.5	5.5	7.5
M10x-044 00170	3	17	7.5	10

For Normal Duty applications, use Heavy Duty ratings.

Heavy Duty

Suitable for demanding applications, current overload of 150 % (60 s) is available for dynamic loads.

Key:

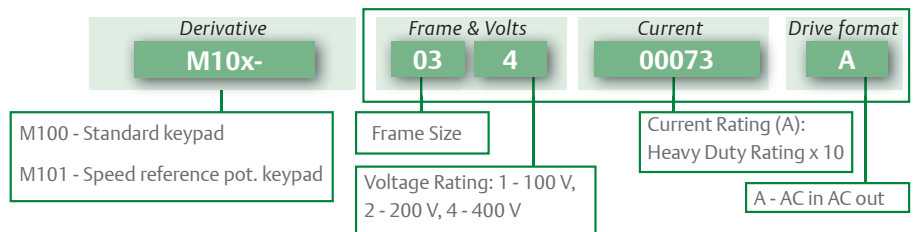

Environmental safety and electrical conformance

- IP21 / UL open class (NEMA 1).
- IP20 when the AI-Back-up Adaptor is fitted.
- UL TYPE 1 compliance requires the appropriate Conduit kit to be fitted.
- Ambient temperature -20 °C (-4 °F) to 40 °C (104 °F) as standard.
Up to 60 °C (140 °F) with derating.
- Storage temperature -40 °C to 60 °C (-40 °F to 140 °F).
- Humidity 95 % maximum (non-condensing) at 40 °C (104 °F) in accordance with EN/IEC 60068-2-78 and ANSI/EIA-364-31.
- EN/IEC 60068-2-60, Method 4 Corrosive gas.
- Altitude: 0 to 3000 m (0 to 9843 ft), derate 1 % per 100 m (328 ft) between 1000 m and 3000 m (3281 ft and 9843 ft).
- Random Vibration: Tested in accordance with EN/ IEC 60068-2-64.
- Mechanical Shock: Tested in accordance with EN/ IEC 60068-2-29.
- Electromagnetic Immunity complies with EN/IEC 61800-3 and EN/IEC 61000-6-2.
- With onboard EMC filter, complies with EN/IEC 61800-3 (2nd environment).
- EN/IEC 61000-6-3 and EN/IEC 61000-6-4 with optional footprint EMC filter.
- EN/IEC 60146-1-1 Supply conditions.
- EN/IEC 61800-5-1 Electrical Safety.
- EN/IEC 61131-2 I/O.
- UL 508C Electrical Safety.

Optional accessories

Description	Order code
AI-Back-up Adaptor	82500000000004

Conduit kit

When the following kits are fitted to the drive, it meets UL Type 1.

Frame size	Order code
1	3470-0091
2	3470-0094
3	3470-0098
4	3470-0102

Retrofit mounting brackets

These mounting brackets ensure the drive can be mounted on existing Commander SK installations.

Frame size	Order code
3	3470-0097
4	3470-0101

Fan replacement kit

Frame size	Order code
1	3470-0092
2	3470-0095
3	3470-0099
4	3470-0103

Optional external EMC filters

Unidrive M built-in EMC filter complies with EN/IEC 61800-3 (2nd environment). External EMC filters are required for compliance with EN/IEC 61000-6-4 as per the table below.

Frame size	Voltage	Phases	Type	Order code	
1	All	1	Standard	4200-1000	
		1	Low leakage	4200-1001	
2	100 V	1	Standard	4200-2000	
		1	Low leakage	4200-2001	
	200 V	1	Standard	4200-2002	
		1	Low leakage	4200-2003	
	400 V	3	Standard	4200-2004	
		3	Low leakage	4200-2005	
3	200 V	3	Standard	4200-2006	
		3	Low leakage	4200-3000	
		3	Low leakage	4200-3001	
	400 V	3	Standard	4200-3004	
		3	Low leakage	4200-3005	
		3	Low leakage	4200-3008	
	4	200 V	3	Standard	4200-3009
			3	Low leakage	4200-4000
			3	Low leakage	4200-4001
400 V		3	Standard	4200-4002	
		3	Low leakage	4200-4003	
		3	Low leakage	4200-4004	
			3	Low leakage	4200-4005

Dimensions and Weight



Frame Size		1	2	3	4
Dimensions (H x W x D)	mm	137 x 75 x 130	180 x 75 x 150	200 x 90 x 160	245 x 115 x 175
	in	5.4 x 3.0 x 5.1	7.1 x 3.0 x 5.9	7.9 x 3.5 x 6.3	9.7 x 4.5 x 6.9
Weight	kg	0.75	1.0	1.5	3.13
	(lb)	(1.65)	(2.2)	(3.3)	(6.9)

Notes:

Height dimension (H) does not include mounting feet.

Additional distance should be added to the height dimension (H) when the following options are fitted:

- AI-Back-up Adaptor: 15 mm (0.59 in)

For a full list of patents and patent applications, visit www.controltechniques.com/patents.

CONTROL TECHNIQUES DRIVE & APPLICATION CENTERS

AUSTRALIA

Melbourne Application Center
T: +61 3 973 81777
controltechniques.au@emerson.com

Sydney Drive Center
T: +61 2 9838 7222
controltechniques.au@emerson.com

AUSTRIA

Linz Drive Center
T: +43 7229 789480
controltechniques.at@emerson.com

BELGIUM

Brussels Drive Center
T: +32 1574 0700
controltechniques.be@emerson.com

BRAZIL

Sorocaba Drive Center
T: +55 15 3413 8169
vendasbrasil.cta@emerson.com

CANADA

Toronto Application Center
T: +1 905 948 3402
controltechniques.ca@emerson.com

Calgary Drive Center
T: +1 403 253 8738
controltechniques.ca@emerson.com

CHILE

Santiago Application Center
T: +56 9 7708 9470
saleschile.cta@emerson.com

CHINA

Shanghai Drive Center
T: +86 21 3418 3888
controltechniques.cn@emerson.com

Shenzhen Application Center
T: +86 755 8618 7287
controltechniques.cn@emerson.com

CZECH REPUBLIC

Brno Drive Center
T: +420 511 180111
controltechniques.cz@emerson.com

DENMARK

Copenhagen Drive Center
T: +45 4369 6100
controltechniques.dk@emerson.com

FRANCE*

Angoulême Drive Center
T: +33 5 4564 5454
controltechniques.fr@emerson.com

GERMANY

Bonn Drive Center
T: +49 2242 8770
controltechniques.de@emerson.com

Chemnitz Drive Center
T: +49 3722 52030
controltechniques.de@emerson.com

Darmstadt Drive Center
T: +49 6251 17700
controltechniques.de@emerson.com

GREECE*

Athens Application Center
T: +0030 210 57 86086/088
controltechniques.gr@emerson.com

HOLLAND

Rotterdam Drive Center
T: +31 184 420555
controltechniques.nl@emerson.com

INDIA

Chennai Drive Center
T: +91 44 2496 1123/1130/1083
T: +91 44 6691 8400
controltechniques.in@emerson.com

IRELAND

Newbridge Drive Center
T: +353 45 448200
controltechniques.ie@emerson.com

ITALY

Milan Drive Center
T: +39 02575 751
controltechniques.it@emerson.com

Vicenza Drive Center
T: +39 0444 933400
controltechniques.it@emerson.com

MALAYSIA

Selangor Drive Center
T: +603 5891 6099
controltechniques.my@emerson.com

MEXICO

Mexico City Application Center
T: +52 155 3333 6666
salesmexico.cta@emerson.com

POLAND

Warsaw Application Center
T: +48 22 45 89 200
controltechniques.pl@emerson.com

REPUBLIC OF SOUTH AFRICA

Johannesburg Drive Center
T: +27 11 462 1740
controltechniques.za@emerson.com

Cape Town Application Center
T: +27 21 556 0245
controltechniques.za@emerson.com

RUSSIA

Moscow Application Center
T: +7 495 981 9811
controltechniques.ru@emerson.com

Chelyabinsk Application Center
T: +7 351 799 5151
controltechniques.ru@emerson.com

Saint Petersburg Application Center
T: +7 812 448 2063
controltechniques.ru@emerson.com

SINGAPORE

Singapore Drive Center
T: +65 6556 1100
controltechniques.sg@emerson.com

SLOVAKIA EMERSON A.S

T: +421 32 7700 369
controltechniques.sk@emerson.com

SOUTH KOREA

Seoul Application Center
T: +82 2 3483 1605
controltechniques.kr@emerson.com

SPAIN

Barcelona Drive Center
T: +34 93 680 1661
controltechniques.es@emerson.com

Bilbao Drive Center
T: +34 94 620 3646
controltechniques.es@emerson.com

Madrid Application Centre
T: +34 91 490 21 05
controltechniques.es@emerson.com

Valencia Drive Center
T: +34 96 154 2900
controltechniques.es@emerson.com

SWEDEN*

Stockholm Application Center
T: +468 554 241 00
controltechniques.se@emerson.com

SWITZERLAND

Zurich Drive Center
T: +41 56 201 4242
controltechniques.ch@emerson.com

Lausanne Application Center
T: +41 21 637 7070
controltechniques.fr.ch@emerson.com

TAIWAN

Taipei Application Center
T: +886 2 8161 7695
controltechniques.tw@emerson.com

THAILAND

Bangkok Drive Center
T: +66 2 962 2099
controltechniques.th@emerson.com

TURKEY

Istanbul Drive Center
T: +90 216 4182420
controltechniques.tr@emerson.com

UAE*

Emerson FZE
T: +971 4 8118100
ct.dubai@emerson.com

UKRAINE

Kiev Application Center
T: +380 44 492 99 29
controltechniques.ukr@emerson.com

UNITED KINGDOM

Telford Drive Center
T: +44 1952 213700
controltechniques.uk@emerson.com

USA

Charlotte Application Center
T: +1 800 893 2321
controltechniques.us@emerson.com

Cleveland Drive Center
T: +1 216 901 2400
controltechniques.us@emerson.com

Detroit Application Center
T: +1 248 882 2652
controltechniques.us@emerson.com

Minneapolis Drive Center
Americas Headquarters
T: +1 952 995 8000
controltechniques.us@emerson.com

Portland Drive Center
T: +1 503 266 2094
controltechniques.us@emerson.com

Providence Application Center
T: +1 401 392 4256
controltechniques.us@emerson.com

LATIN AMERICA

Miami Application Center
T: +1 954 846 5082
saleslatinam.cta@emerson.com



The Emerson logo is a trademark and a service mark of Emerson Electric Co. ©2012 Emerson Electric Co.

DRIVING THE WORLD...

CONTROL TECHNIQUES DISTRIBUTORS

ARGENTINA

Euro Techniques SA
T: +54 11 4331 7820
eurotech@eurotechsa.com.ar

BAHRAIN

Emerson FZE
T: +971 4 8118100
ct.bahrain@emerson.com

BULGARIA

BLS - Automation Ltd
T: +359 32 630 707
info@blsaautomation.com

COLOMBIA

Sistronic SAS
T: +57 2 555 6000
luis.alvarez@sistronic.com.co

Redes Electricas S.A.
T: +57 1 364 7000
alvaro.rodriguez@redeselectricas.com

Quimel Colombia S.A.
T: +57 1 547 5215
gerencia@quimelco.com

CROATIA

Zigg-Pro d.o.o.
T: +385 1 3463 000
zigg-pro@zg.tinet.hr

CYPRUS

Acme Industrial Electronic Services Ltd
T: +3572 5 332181
acme@cytanet.com.cy

DOMINICAN REPUBLIC

Puradom S.A.
T: +1 809 565 9599
franco@puradom.com

EGYPT

Samiram
T: +202 29703868/
+202 29703869
samiramz@samiram.com

EL SALVADOR

Servielectric Industrial S.A. de C.V.
T: +503 2278 1280
aeorellana@gruposervielectric.com

ECUADOR

Veltek Cia. Ltda.
T: +59 3 2326 4623
vacosta@veltek.com.ec

FINLAND

SKS Control
T: +358 207 6461
control@sks.fi

GUATEMALA

MICE S.A.
T: +502 5510 2093
cesar.espana@miceautomation.com

HUNGARY

Control-VH Kft
T: +361 431 1160
info@controlvh.hu

ICELAND

Samey ehf
T: +354 510 5200
samey@samey.is

INDONESIA

PT. Apikon Indonesia
T: +65 6556 1100
controltechniques.sg@emerson.com

PT. Yusa Esa Sempurna Sejahtera

T: +65 6556 1100
controltechniques.sg@emerson.com

ISRAEL

Dor Drives Systems Ltd
T: +972 3900 7595
info@dor1.co.il

KENYA

Kassam & Bros Co. Ltd
T: +254 2 556 418
kassambros@africaonline.co.ke

KUWAIT

Emerson FZE
T: +971 4 8118100
ct.kuwait@emerson.com

LATVIA

EMT
T: +371 760 2026
janis@emt.lv

LEBANON

Black Box Automation & Control
T: +961 1 443773
info@blackboxcontrol.com

LITHUANIA

Elinta UAB
T: +370 37 351 987
sales@elinta.lt

MALTA

Mekanika Limited
T: +35621 442 039
mfranca@gasan.com

MOROCCO

Cietec
T: +212 22 354948
cietec@cietec.ma

NEW ZEALAND

Advanced Motor Control. Ph.
T: +64 (0) 274 363 067
info.au@controltechniques.com

PERU

Intech S.A.
T: +51 1 348 5858
ventas@intech-sa.com

Tecno Ingeniería Industrial SAC

T: +51 1 445 3608
jforero@tecnoing.com

PHILIPPINES

Control Techniques Singapore Pte. Ltd.
T: +65 68917600
controltechniques.sg@emerson.com

POLAND

APATOR CONTROL Sp. z o.o
T: +48 56 654 4900
info@acontrol.com.pl

PORTUGAL

HARKER SOLUTIONS, S.A.
Tel: +351 229 478 530
geral@harkersolutions.com

PUERTO RICO

Motion Industries Inc.
T: +1 787 251 1550
roberto.diaz@motion-ind.com

Control Associates of Puerto Rico LLC
T: +1 (787) 783 9200
pr-sales@control-associates.com

QATAR

Emerson FZE
T: +971 4 8118100
ct.qatar@emerson.com

ROMANIA

C.I.T. Automatizari
T: +40212550543
office@citautomatizari.ro

SAUDI ARABIA

A. Abunayyan Electric Corp.
T: +9661 477 9111
aec-salesmarketing@abunayyanguroup.com

SERBIA & MONTENEGRO

Master Inzenjering d.o.o
T: +381 24 525 235
office@masterinzenjering.rs

SLOVENIA

PS Logatec
T: +386 1 750 8510
ps-log@ps-log.si

URUGUAY

SECIOIN S.A.
T: +5982 2093815
jose.barron@secioin.com.uy

VENEZUELA

Digimex Sistemas C.A.
T: +58 243 551 1634
digimex@digimex.com.ve

VIETNAM

Nguyen Duc Thinh Technology & Trading Co. Ltd.
T: +84 8 3916 5601
infotech@nducthinh.com.vn